

8 各部零件說明 Description

ICS-321
CS4 RIS Crane Stock EBB

*每一款槍型基本配備不同依實際出貨為主。圖片僅供參考。
The components/accessories for each model may have kind of differences depending on the actual goods. Images are only for reference.

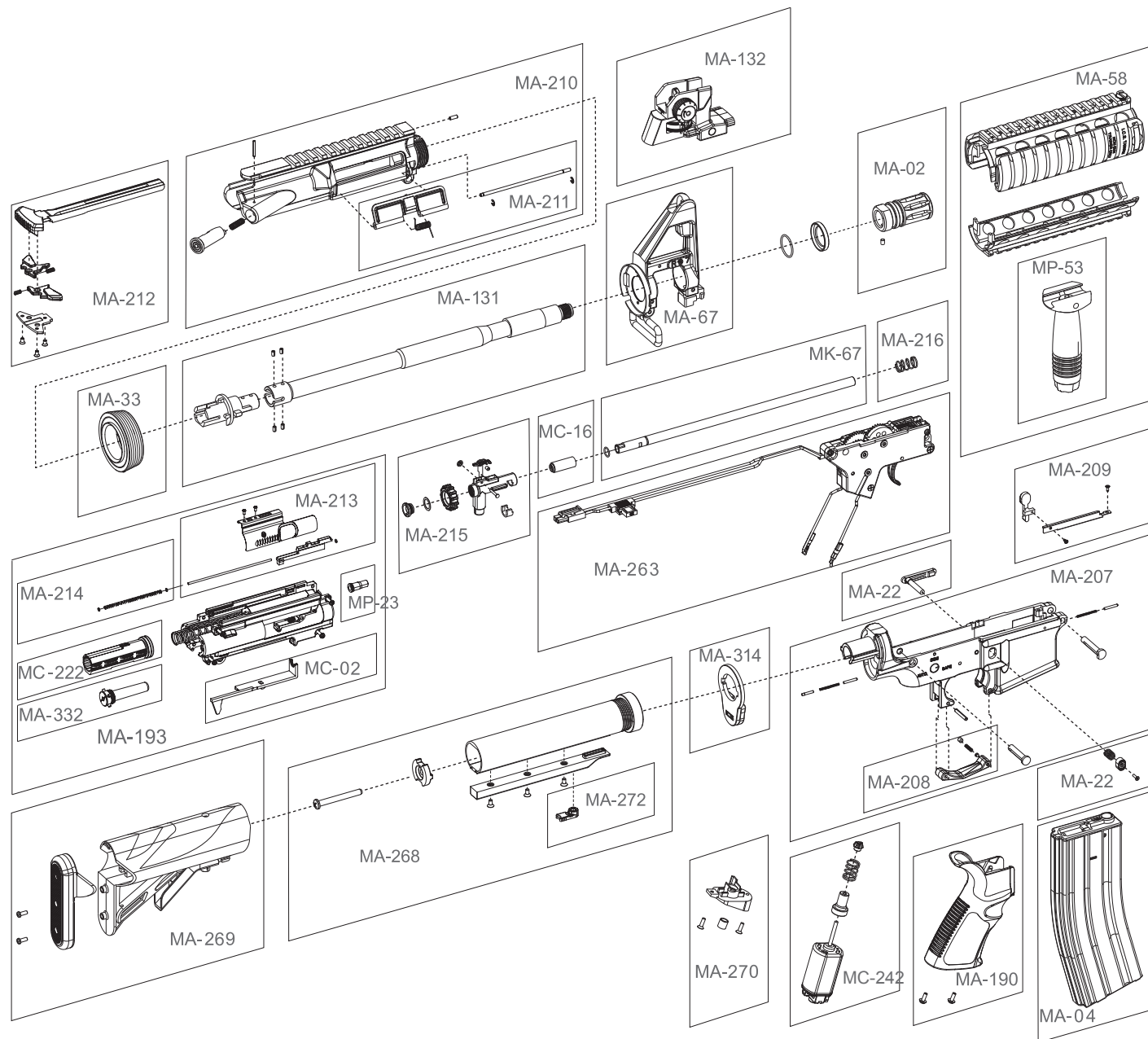

Patents acquired: US 7077117 B1/R.O.C M244431/R.O.C M320468/ R.O.C. M480664 / R.O.C. M351340

WARNING 警告 電槍使用之注意事項 Maintenance

1. 請勿使用劣質或回收BB彈，以減少槍管損耗及避免卡彈。
2. 一旦發生卡彈或射擊速度降低時，應立即停止射擊，以避免齒輪過度耗損。請使用通槍條將殘彈清除，或被測電池電量後方可繼續使用。
3. 不使用本產品時，請務必將射擊選擇鈕置於保險(S)的位置上，將電池移除並定期使用通槍條清潔槍管。
4. 請依原廠附贈之保險絲規格使用。不當配置可能導致零件故障，槍內配置M100彈簧請用20A保險絲，M120彈簧請用25A保險絲。
5. 彈頭直徑6mm。其槍口動能為二焦耳以下、射程範圍為50公尺以內。
6. 適用年齡為18歲以上。
7. 使用本商品不得改造或變態，並不得使用金屬彈頭。
8. 「此槍非玩具」，濫用可能造成嚴重傷害，尤其是眼睛。使用時應確保本身及射程範圍內所有人員均已確實穿戴護目鏡。
9. 使用方法及注意事項請詳閱說明書內容。
10. 建議使用以下電池以達到最大效益：
SSS系統建議使用7.4v & 11.1v Li-Po電池。
傳統電阻與FET電阻系統11.1v LiPo電池Ready。
※使用非建議電池可能會造成產品效能低落、功能異常甚至損毀。
(原產地：台灣 / 製造商：一芝軒企業有限公司 / 地址：台中市神岡區東洲路79巷67號 / 電話：04-25256461)

1. To reduce the abrasion of inner barrel and to avoid BB jam, please do not use inferior or reused BB pellets.
2. If your gun is jammed or the muzzle velocity has decreased, please stop shooting immediately in case the gear abrades excessively. Use the clearing rod to clear out the remaining pellets, or check your battery power before continue using your gun.
3. Please engage the safety, dismount the battery and clear the inner barrel with the clearing rod periodically when not using this product.
4. Please use the same fuse specification as the original one. Equipping improper fuse might cause malfunction to the components. Apply 20A fuse if the gun using a M100 spring; apply 25A fuse if using M120 spring.
5. The diameter of the BB pellet is 6mm. The muzzle energy is less than two joules, and the shooting range is within 50 meters.
6. The recommended age to operate this product is 18 years old and above.
7. Modify, reform, and using metal bullets on this product are strictly forbidden.
8. This is NOT a toy. Abusing might cause severe injuries, especially to the eyes. Before operating, please make sure that every personnel in the shooting range have worn eye protections properly, including the operator.
9. Please read the manual for instruction and precaution.
10. In order to achieve the maximum performance, the following batteries are recommended:
SSS system: 7.4v or 11.1v Li-Po batteries.
Traditional switch and FET switch system: 11.1v Li-Po battery Ready.
※Using non-recommended batteries may cause poor performance, abnormal functions or even damage to the product.
Origin: Taiwan/ Manufacturer: ICS enterprise Co., Ltd / Address: No.67, Ln. 79, Dongzhou Rd., Shengang Dist., Taichung City 429, Taiwan / TEL : (+886) 4-2525-6461



1 各部名稱 Series Component

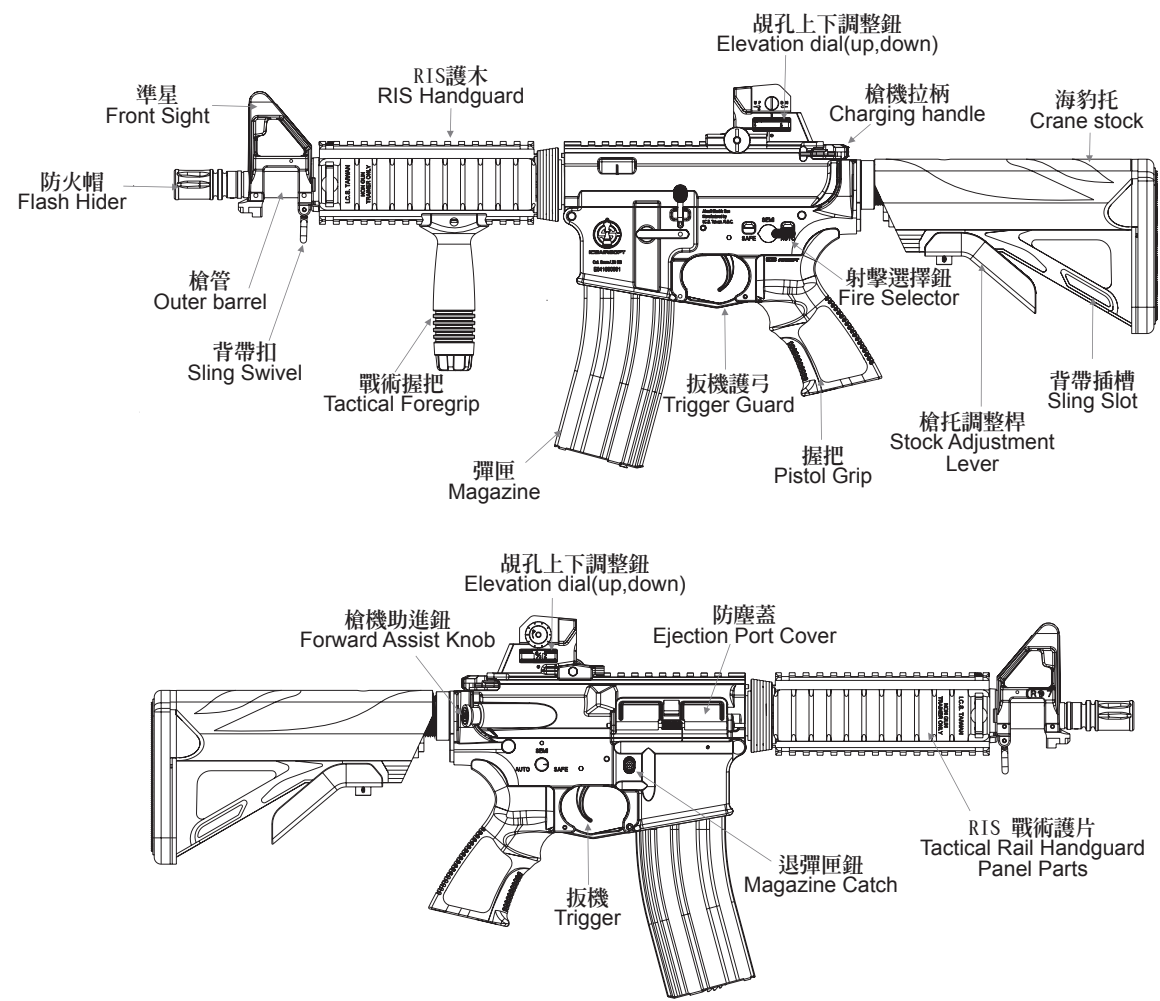

2 彈匣使用方式 Magazine Attachment

2-1 裝BB彈方式 Load BBs

將彈匣上蓋依箭頭方向打開再倒入BB彈。
Open the cover to load BBs.

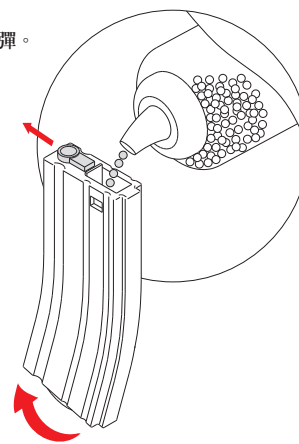

建議使用 6mm BB彈。
6mm caliber BBs are recommended for optimum performance.

依箭頭方向旋緊彈匣底下旋鈕，即可將BB彈順利送出。
To charge BB feed spring, please rotate the gear under the magazine.

2-2 裝卸彈匣 Magazine Loading and Unloading

1. 直接將彈匣插入彈匣插槽。
2. 按壓退彈匣片即可將彈匣卸下。

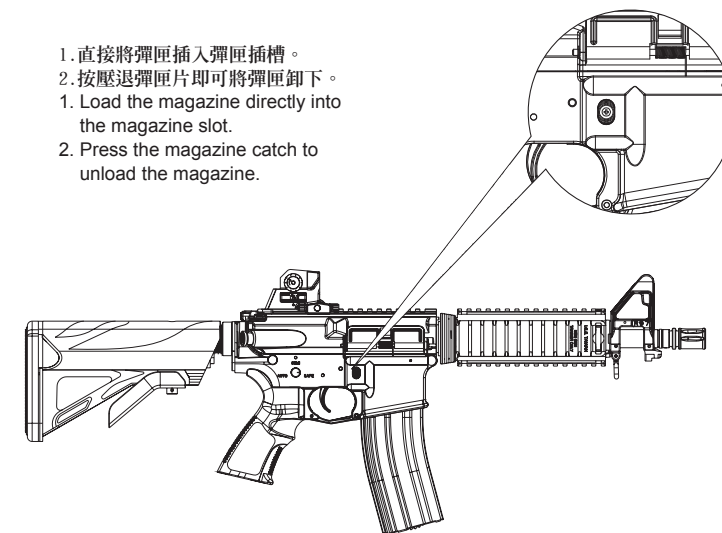

3 可動部的說明 Movable Parts

3-1 可作動作 Movable Parts

拉柄拉動可打開防塵蓋
Pull the charging handle to open the ejection port cover.

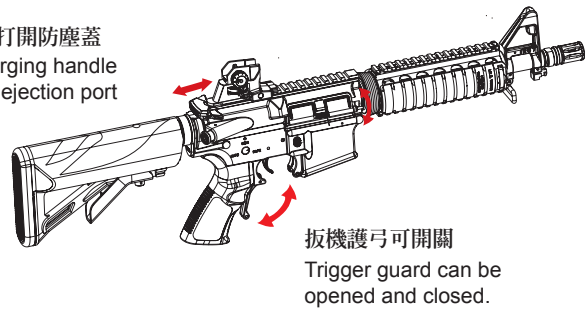

扳機護弓可開關
Trigger guard can be opened and closed.

3-3 快拆尾頂桿 QD Spring Guide

1. 使用4mm六角板手，對準尾頂桿往內推入後旋轉45度
2. 將尾頂桿與彈簧抽出

※安裝彈簧後依照步驟1倒序組裝

1. Use 4mm Allen key, insert it to the spring guide and then press down to turn 45 degrees.
2. Take out the spring guide and spring.

※ Reverse the above steps to install spring.

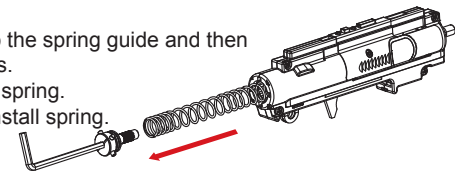

3-2 槍身結合3號齒正確位置圖 The correct position of sector gear before reassembling

注意 未進行歸位校正，會損壞活塞及齒輪

※ The piston and gear may be damaged without correcting the position in advance.

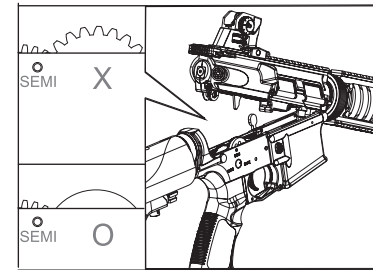

3號齒在槍身結合時，必須轉到正確位置，才可將上槍身蓋下。

Make sure the sector gear is turned to the correct position before reassembling the receiver.

3-4 調整伸縮托長度 Adjust Retractable Stock Length

按壓槍托調整桿，即可將伸縮托向後拉或向前推，共有6段可供調整長度。
Press and hold the stock adjustment lever to adjust stock length forward and backward. A total of 6 lengths are available for adjustment.

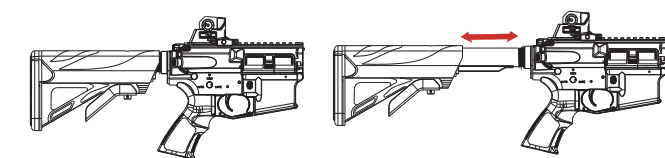

4 精確射擊調整動作 Precision Targeting Adjustment

4-1 覘孔調整 Rear Sight Adjustment

A: 瞄準距離遠近調整 Aiming distance adjustment

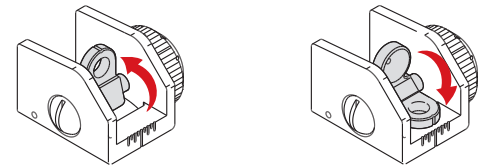

近距：將覘孔往前推。
For close range, Flip sight forward.

遠距：將覘孔往後推。
For far range, Flip sight backward.

B: 覘孔高度調整 Height adjustment

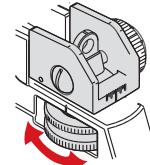

將調整鈕左右轉動即可調整覘孔組高低。
Push the dial forward to raise the sight.
Push the dial backward to lower the sight.

C: 覘孔左右調整 Windage adjustment

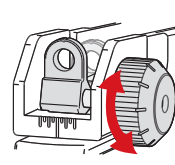

依旋鈕方向旋轉即可將覘孔組左右調整。
Rotate clockwise to aim right.
Rotate counter clockwise to aim left.

4-2 選擇射擊模式 Shooting Mode Setting

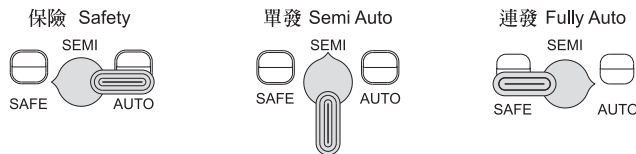

※此系列產品具備「關保險自動釋放彈簧功能」。

1. 槍上有彈匣的情況下，關保險會自動釋放彈簧，有機率造成第一發雙彈射出或者小便彈，屬正常情況。
2. 槍枝使用完畢，請轉至單發模式下，擊發2-3下後做清槍動作，再關保險確保槍管內已無殘彈。
3. 上下槍身分解前，務必先關保險釋放彈簧，避免造成齒輪倒轉損壞活塞。

※關保險自動釋放，可延長彈簧壽命，避免長期擠壓造成疲乏

※ This product is equipped with an auto spring tension releases mechanism in the safety mode.

1. Having a magazine loaded, it is a normal condition that the gun might shoot a double shot, or a weak shot after turning it to safety and releasing the tension stored in the spring.
2. After finishing playing, fire the gun 2-3 times in semi auto to clear the remaining BBs inside the hop-up chamber, then switch the selector lever to safety to ensure there is no BB left inside.
3. Before opening the upper and lower receivers, always release the spring tension by turning the selector lever to safety position, this will avoid spring damage from sudden release from the sector gear.

※ The spring tension release mechanism can extend the spring lifetime by avoiding spring fatigued from long time compression.

5 H-UP 彈道調整 H-UP Adjustment

注意 非必要時，手指請勿放置於H-UP調整處，避免受傷

※ To avoid injuries, only put your finger on the H-up adjustment when necessary.

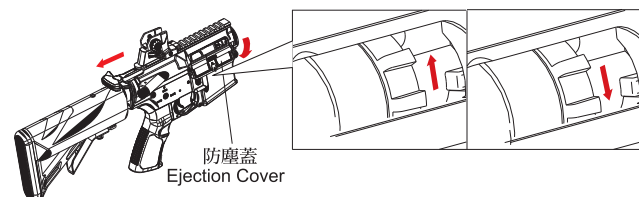

1. 將槍機拉柄往後拉(不可放開)，防塵蓋下翻、槍機飾片向後打開，即可進行彈道調整。
2. 視彈道進行撥盤調整，調整完即可放開槍機拉柄。

1. To adjust the trajectory, pull and hold the charging handle to the end (do not release) to open the ejection port cover downward, and open the decorated bolt plate backward.
2. Rotate the dial to adjust the trajectory. Release the charging handle once you finished the adjustment.

H-UP調整：BB彈呈現一直線的彈道才是正確射法。

過於上飄：將撥盤向上旋轉。

過於下墜：將撥盤向下旋轉。

H-up Adjustment: Make sure the trajectory of the BB pellets to be straight.

When the BB pellet flies up: Rotate the dial counter-clockwise to lower the trajectory.

When the BB pellet falls down: Rotate the dial clockwise to raise the trajectory.

6 電池的拆裝方法 Battery Installation and Disassembly

注意 重新組裝時，必須依反向動做組合

※ Reassembling is the reverse of disassembling procedures.

6-1 電池安裝方式 Battery fitting method

1. 旋開槍托底部螺絲
2. 拆下槍托底板
3. 即可安裝電池
4. 將槍托調整桿向下拉開後，即可取出槍托
5. 將護木固定環依方向往後拉
6. 再將護木上下分離並卸下。

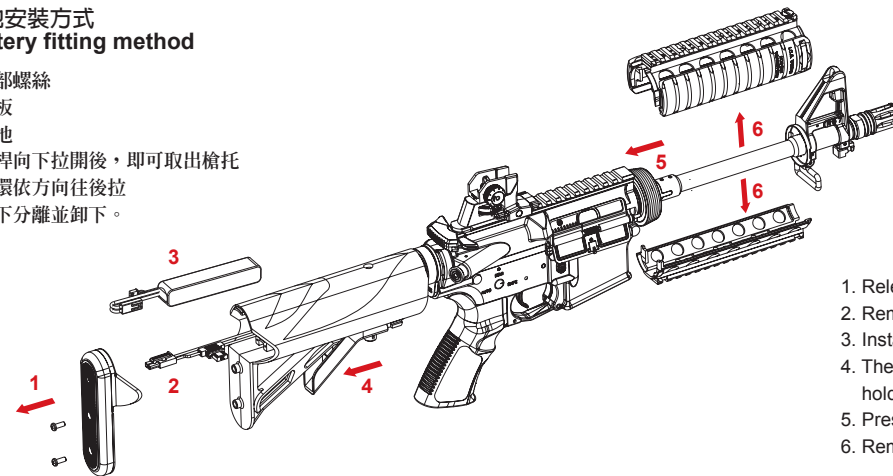

1. Release the screws on the butt plate.
2. Remove the butt plate.
3. Install battery.
4. The stock can also be removed by pressing and holding the stock release lever to install battery.
5. Press and hold the delta ring backward.
6. Remove the RIS handguard.

6-2 戰術握把調整方式 Tactical Foregrip Adjustment

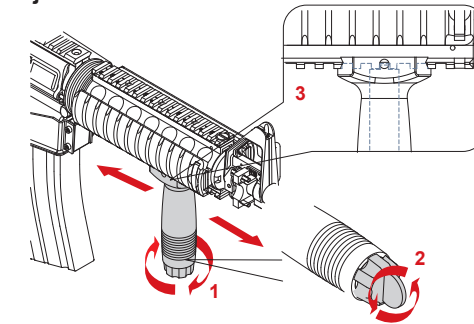

1. 依順時針方式鬆開握把旋鈕，即可前後調整握把位置。
2. 可使用銅板或手將握把旋鈕鬆開
3. 固定銷對準軌道條上的凹槽，再將旋鈕鎖緊

1. Lose the joint dial to adjust the foregrip to personal preference.
2. Use a coin or by hand to lose the dial.
3. Make sure the grooves on the foregrip are properly in position.

7 齒輪箱拆解 Disassemble Gearbox

注意 先卸彈匣跟電池，再進行拆解

※ Unload the magazine and battery before you proceed to disassemble.

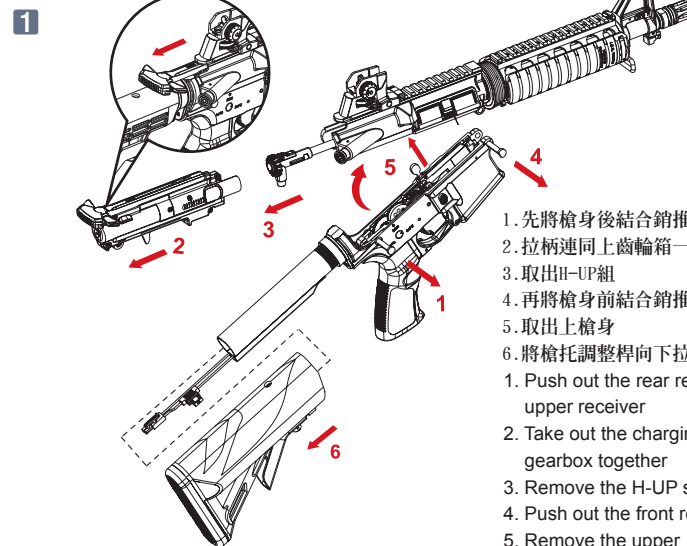

1. 先將槍身後結合銷推出即可打開上槍身
2. 拉柄連同上齒輪箱一同取出
3. 取出H-UP組
4. 再將槍身前結合銷推出
5. 取出上槍身
6. 將槍托調整桿向下拉開後取出槍托

1. Push out the rear receiver pin to separate the upper receiver
2. Take out the charging handle with upper gearbox together
3. Remove the H-UP set
4. Push out the front receiver pin
5. Remove the upper
6. Pull the stock release lever then pull out the stock

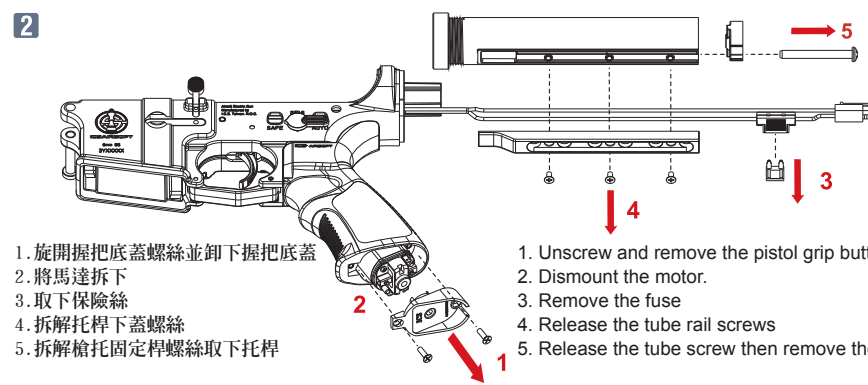

1. 旋開握把底蓋螺絲並卸下握把底蓋
2. 將馬達拆下
3. 取下保險絲
4. 拆解托桿下蓋螺絲
5. 拆解槍托固定桿螺絲取下托桿

1. Unscrew and remove the pistol grip butt cap.
2. Dismount the motor.
3. Remove the fuse
4. Release the tube rail screws
5. Release the tube screw then remove the tube

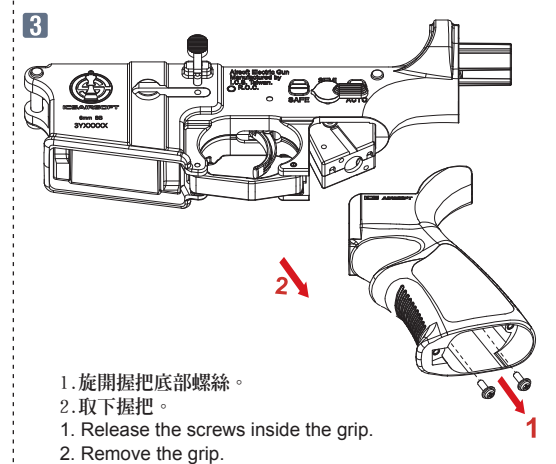

1. 旋開握把底部螺絲。
2. 取下握把。

1. Release the screws inside the grip.
2. Remove the grip.

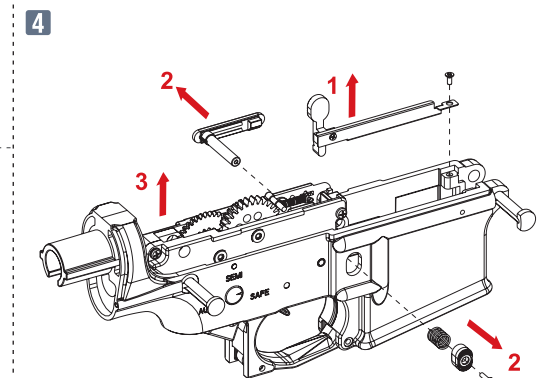

1. 旋開線槽螺絲。
2. 旋開彈匣卡榫螺絲並取下。
3. 將下齒輪箱取出

1. Release the screw on wire guard assembly.
2. Remove the screw on the magazine catch button.
3. Take out the lower gearbox.