

MT1



AAKCMD55 系說明書 AAKCMD55 INSTRUCTION MANUAL

KWC KIWEN WELL TOY INDUSTRIAL CO., LTD
www.kwcgun.com

台南市仁德區義林路168巷89號
NO.89, LN. 168, YILIN RD.,
RENDE DIST., TAINAN CITY
71752, TAIWAN (R.O.C.)
TEL : +886-6-2798175
FAX : +886-6-2798176
sales@kwcgun.com
www.kwcgun.com



操作/OPERATION

操作說明

OPERATION

1. 取出彈匣
RELEASE MAGAZINE



1. 推開卡榫
Push the button

2. 取出彈匣
Release the magazine

▲注意：請勿使彈匣直接掉落地面，以防止變形或損壞。

▲CAUTION: Magazine falling directly on the ground could cause deform or damage on it. Please be aware.

2. CO2小鋼瓶12g的使用
INSTALLING 12G CO2 CARTRIDGE

逆時針轉出彈匣底內件後，置入小鋼瓶B，再以順時針方向鎖緊彈匣底內件A。當刺破鋼瓶出氣時，請快速鎖緊。
Turn the magazine cap out counter-clockwise and place CO2 cartridge B inside the magazine. Rapidly turn the screw A clockwise when piercing the cartridge in the magazine.

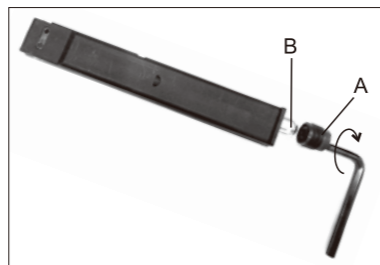

▲注意：為維護彈匣使用壽命，請盡可能不要殘留CO2氣體於彈匣內。

▲CAUTION: To protect your magazine, please release all of the CO2 out of the magazine after every use.

3. 填裝BB彈
LOADING BBs
為了使擊發順暢，填裝方法是讓B.B彈在彈匣中一粒接著一粒。
For smooth shooting, Load BBs one by one.

▲注意：彈匣最多可裝39發B.B彈，如強行裝入更多，可能造成不當損壞及無法上膛，請注意。

▲CAUTION: Magazine max capacity is 39 rounds. Loading more than this quantity could bring malfunctions.

射擊

SHOOTING

1. 將裝好BB彈的彈匣插入槍身上推入，直到彈匣卡榫發出"卡嗒"為止。
Insert fully loaded magazine in the airgun until you hear the sound of "CLICK".



2. 瞄準目標物扣引扳機，即可擊發。
Aim the target and pull the trigger.



保險切換 SWITCH SAFETY

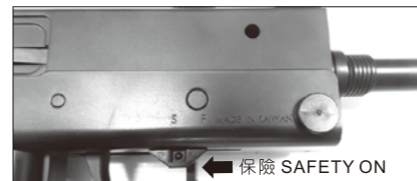

拆解/DIS-ASSEMBLY

1. 拆解前退下彈匣
Remove the magazine before disassemble.
2. 再將槍托如圖所示，先往左壓住推開，讓卡榫脫離孔洞
Press stock to release the catch as picture.



3. 槍托扳開往下，在槍尾端下面有顆拉桿按鈕，請直接壓住後把槍托拉出來
Push down the stock until click sounds. Press the button as picture to pull out the stock.

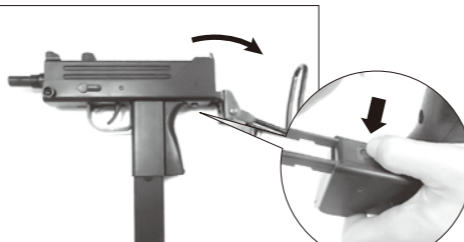

4. 槍托拉開到底
Pull out the stock rod.



5. 持續按住就可將槍托拉出
Hold the button to release stock.

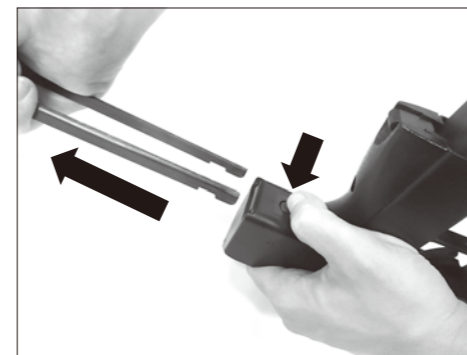

6. 移除槍身前端的插銷和軸
Remove frame bolt and frame pin.



7. 接著把保險按鈕往前推，直接右移取出
Push the safety forward and remove it.



8. 槍尾端的拉桿按鈕壓入槍身內
Push the stock catch into the frame.

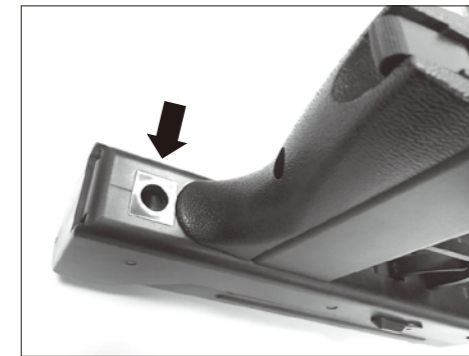

9. 拆解分離完成
Disassembly done.



故障的原因與排除

BREAK DOWN FAQ

- * 卡彈可能原因：
the reason for BB jam :
- a. 裝彈排列不整齊
the BB in the magazine does not arrange very well.
- b. 不良B.B彈
bad quality BB



- * 排除：此時並非故障，只需重新上膛便可繼續使用。
Solution: This is not a failure. Just reload and operate again.

* 保養及維護 MAINTENANCE GUIDE

當射擊約2000發時，建議你如圖所示，以矽油脂適當在上蓋與本體滑動接觸面及擊鐵、撞針作動處潤滑，以利滑動。
After every 2,000 BB shots, lubricating the Firing pin and Track as pictures below is recommended.

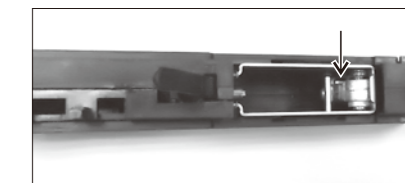

⚠️ WARNING 注意事項

請務必嚴格遵守 使用說明指導書 READ THIS OWNER'S MANUAL COMPLETELY.

此玩具槍是針對喜愛射擊運動的消費者所開發。避免因使用方法不正確或改造所發生的故障或事故，請務必詳讀說明書，正確的操作享受愉快的射擊運動。

- 除了發射時外，不要將手指頭掛在板機上。
- 在非使用期間，請保持保險關閉且退彈的狀態。
- 如任何的機械產品，槍的保險也可能失效。即使在保險關閉的狀態下也請小心的操作此槍，請勿將槍口對人。
- 請妥善保管產品在未未成年孩童無法伸手取得的場所。
- 每次使用前後都應該檢查防護措施，假如防護措施表面有失效請停止使用。
- 請使用高品質BB彈，請勿使用①口徑大於4.4mm②表面不平滑的③重複使用過的BB彈④非本說明書指名的發射物。
- 最高的使用及儲藏CO2小鋼瓶環境為50°C(122°F)以內，高溫可能會造成CO2小鋼瓶過熱甚至爆炸。
- 空擊發易造成零件損耗，請避免此動作。

This airgun is intended for recreational or training purposes. To prevent improper handling, modification or alteration causing malfunction or accident, please read the owner's manual carefully. Enjoy the pleasant shooting experience by proper operation.

- Do not put your finger on the trigger except shooting.
- Please always keep the airgun on safe and unloaded when not using.
- Like all mechanical devices, an airgun safety can fail. Always handle the airgun safely even when the safety is "on safe". Never point the airgun at any people.
- Keep the airgun out of reach for small children.
- Your backstop should be inspected for wear before and after each use. Discontinue use of the backstop surface shows signs of failure.
- Only use high quality 4.5mm steel BBs. Never use ①BB diameter larger than 4.4 mm②BB with unsmoothed surface③reused BB that has been fired④incorrect projectiles not design for this airgun
- Do not expose CO2 cartridges to heat or store them at temperatures above 50°C(122°F). CO2 cartridges may over heat or explode at temperatures above 50°C(122°F).
- Please avoid dry firing, for it could cause parts deformed or damage.

★使用玩具槍前，請務必戴上保護眼鏡或面罩。
★Always wear eye protection when using airgun.

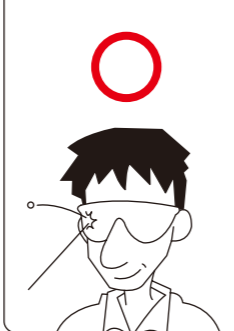

★使用玩具槍前，請務必詳讀說明書內容。
★Read the owner's manual before using the airgun.



★不可攜帶玩具槍在公共場所行走，請務必裝在袋子或盒子內。
★Always transport an airgun in a locked carrying case. Make sure it is unloaded and on safe.

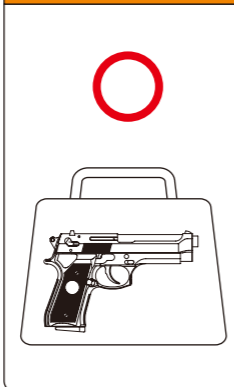

★請不要由槍口向內探視。
★To Avoid accidental discharge, do not look directly into the barrel.



★請不要在公開場合使用玩具槍，也請不要拿玩具槍對準人或動物。
★Never brandish or aiming this airgun at any people or domestic animals. Brandish this airgun in public is dangerous and may be a crime.

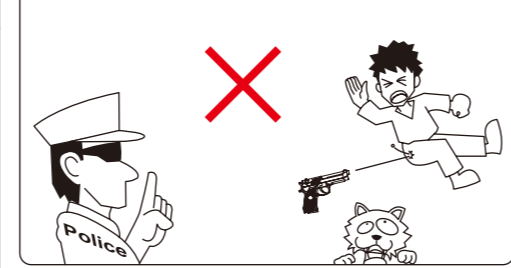

★請確認後再發射BB彈方向，附近無人或動物存在。
★Always be aware of your surrounding before and during shooting and select a safe area for target practice.

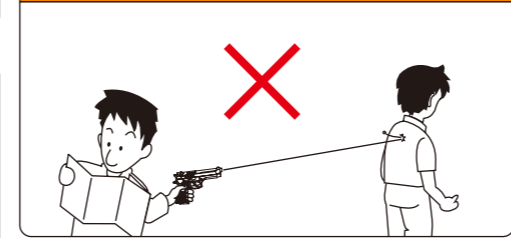

★不可任意改造或加工玩具槍，私自改造加工會造成產品損壞、保固失效，導致使用上不安全，甚至觸法送辦。
★Disassemble, modify, or alter of your airgun may cause malfunction, void your warranty and may make it unsafe to use.



Do not display this pistol in public—it may confuse people and may be a crime. 請不要忘了，雖然自己知道這只是玩具，但不知道的人，會以為這是真槍。

AAKCMD55 系列 零件表 AAKCMD55 SERIES PARTS LIST

N O.	零件名稱	UNIT
P02	槍身握柄	GRIP
P03	擊鐵箱右	BARREL TOW R
P04	擊鐵箱左	BARREL TOW L
P05	保險	SAFETY
P06	保險支桿	SAFETY LEVER
P07	拉柄	COCKING HANDLE
P08	前準星	FRONT SIGHT
P09	槍身下部軸	FRAME PIN
P10	槍身下部插銷	FRAME BOLT
P11	彈匣卡筍	MAGAZINE CATCH
P13	槍管套(小孔)	
P16	槍管內套	
P17	彈匣底座配件	MAGAZINE BASE JOINT
P18	彈匣滑粒	MAGAZINE FOLLOWER
P19	槍身本體	FRAME
P20	彈匣(4.38)	MAGAZINE
P21	KG-47 彈匣底內件	MAGAZINE BOTTOM CAP
P22	UKG-01 心棒蓋迫緊	VALVE PACKING
Z02	槍管連動件	BARREL TOW
Z03	扳機	TRIGGER
Z04	扳機連動件	TRIGGER TOW
Z05	撞針	FIRING PIN
Z06	槍托座拉桿	STOCK ROD
Z07	拉桿定位件	STOCK CATCH
F01	扳機連桿	TRIGGER BAR
F02	槍托	STOCK
F03	彈匣卡榫軸	MAGAZINE CATCH PIN
F04	擊鐵箱軸	HAMMER CASE PIN
F05	KG-47 心棒壓簧墊圈	VALVE SPRING GASKET
F02	子彈迫緊	RUBBER CHAMBER

N O.	零件名稱	UNIT
R03	0形環 1x4	O-RING 1X4
R04	0形環 11X1	O-RING 11X1
R05	0形環1.45X6.9id	O-RING 1.45x6.9id
R06	0型環1X7 NBR70	O-RING 1X7
R07	0形環 2X15	O-RING 2X15
B02	撞針軸	HAMMER PIN
B03	內槍管	INNER BARREL
B04	扳機軸	TRIGGER AXIS
B05	扳機連動件軸	TRIGGER CONNECTOR PIN
B06	心棒蓋	VALVE CAP
B08	KG-15氣瓶頂針(短彈匣用)	INNER VALVE
B09	氣瓶頂針迫緊	CO2 INNER VALVE PACKING
B10	RKM系 心棒(二孔)	
B11	槍托軸	STOCK PIN
B12	槍托定位軸	STOCK POSITION PIN
B13	槍托墊圈	STOCK WASHER
S01	扳機連桿扭簧	TRIGGER BAR SPRING
S02	撞針回位扭簧	HAMMER SPRING
S05	彈匣卡榫壓簧	MAGAZINE CATCH SPRING
S06	拉桿定位件壓簧	STOCK CATCH SPRING
S07	撞針扭簧	FIRING PIN SPRING
S08	彈匣壓簧	MAGAZINE SPRING
S09	槍管回位壓簧	BARREL SPRING
S10	KG-47 心棒壓簧	VALVE SPRING
E01	槍身握柄螺絲	SCREW
E02	⊕皿 2.3x6束黑熱	SCREW
E03	⊕2.3x 6尖黑熱	SCREW
E04	⊕2.3x 6尖.鉸.熱	SCREW
E06	E型扣環	E BUCKLE

AAKCMD55 系列 零件分解圖 AAKCMD55 SERIES EXPLODED VIEW

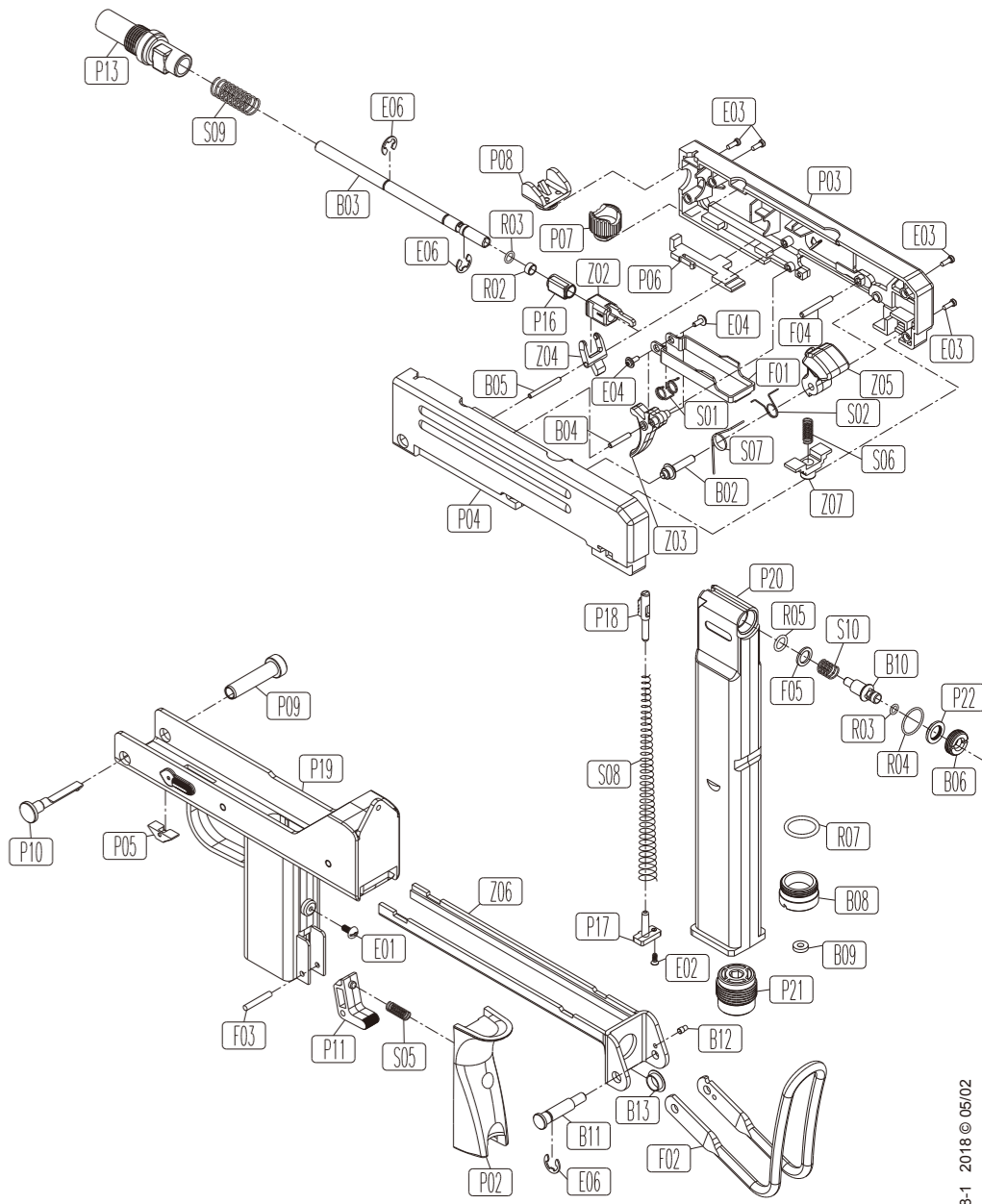

※零件有時為了改良而不經預告變更。
※Due to improvement, spare parts could be modified without notification.