

# WARNING: BEFORE USAGE, THE INSTRUCTION MUST BE READ.

THANK YOU FOR PURCHASING. THE FOLLOWING ATTENTION POINTS AND INSTRUCTIONS MUST BE READ. SHOOTING WITHOUT CAUTION OR USED IMPROPERLY, BLINDNESS OR INJURIES COULD BE LEAD.

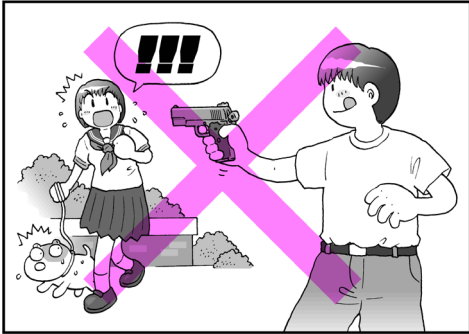

DO NOT POINT AT PEOPLE OR ANIMAL.



GUN AND GAS MUST NOT BE PLACED IN AREA WHERE TEMPERATURE IS OVER 40 °C

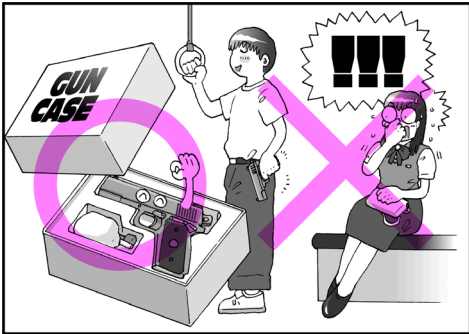

PLACE IN GUN CASE WHEN NOT IN USING OR TRANSPORTING



DO NOT USE GAS WHICH PRESSURE IS OVER 12 Kgs/cm<sup>2</sup>

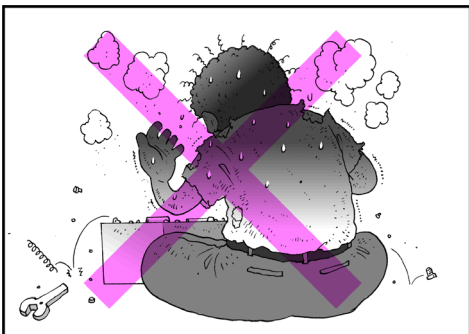

UNAUTHORIZED RECONSTRUCTION OF AIR SOFT GUN TO STRENGTHEN FIRING FUNCTION IS STRICTLY PROHIBITED.



BE CAREFULL WHAT TARGET YOU SHOOT



EYE PROTECTION DEVICE MUST BE EQUIPPED



DO NOT LOAD ANYTHING BUT BB BULLETS.

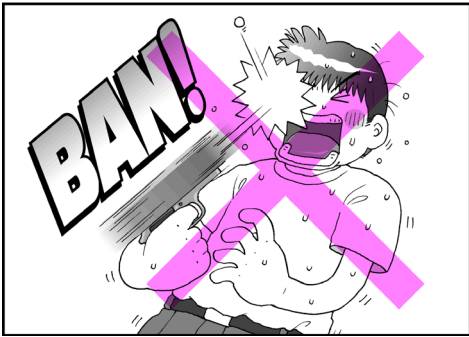

DO NOT LOOK THROUGH THE BARREL



PLEASE SHOOT IN SAFE PLACE

## OPERATION

### 1. REMOVE THE MAGAZINE

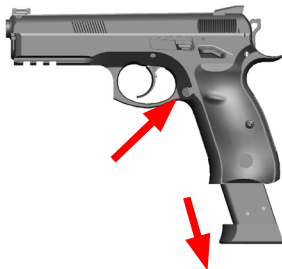

PRESS MAGAZINE CATCH AND REMOVE MAGAZINE

### 2. FILLING GAS

GAS MAG

CO2 MAG

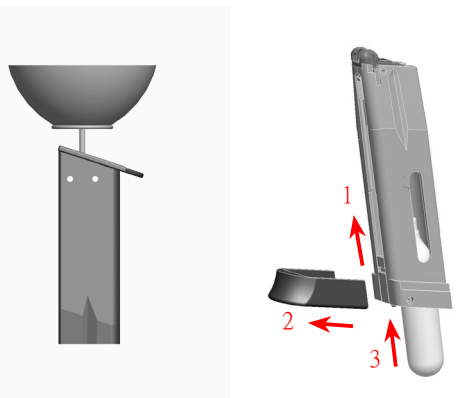

GAS MAG:

FILL THE GAS BOTTLE TO THE MAGAZINE IN VERTICAL DIRECTOR.

CO2 MAG:

Follow the instruction to insert the cartridge

### 3.LOAD BB

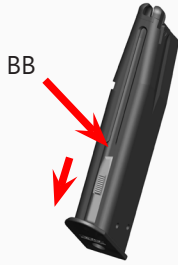

PULL DOWN FOLLOWER AND LOAD BB.

### 4 INSERT MAGAZINE



### 5.LOAD



PULL THE SLIDE TO LOAD

### 6.FIRE



PULL THE TRIGGER

### 7.SAFETY

SAFETY ON

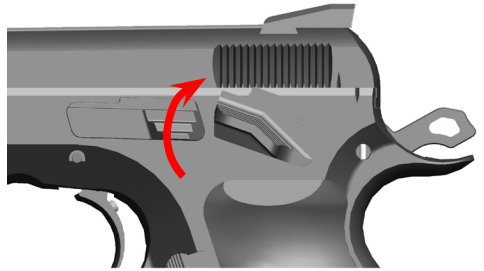

SWITCH TO ON POSITION

SAFETY OFF

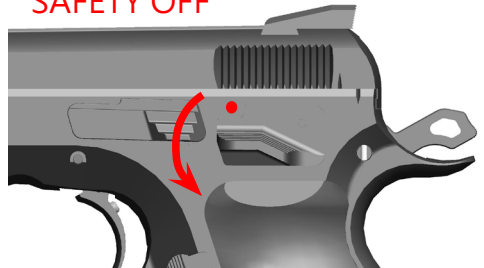

SWITCH TO OFF POSITION

# DISASSEMBLY

1. PULL BACK SLIDE TO THE POSITION AND TAKE OUT THE SLIDE STOP



2. REMOVE THE SLIDE



3. REMOVE THE RECOIL SPRING AND GUIDE

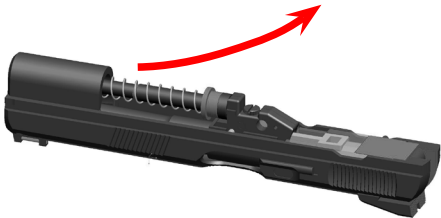

4. REMOVE THE BARREL

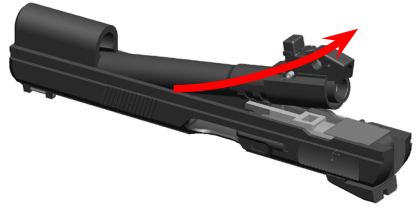

# ASSEMBLY

REVERSE THE DISASSEMBLY  
ADJUST TREJECTORY

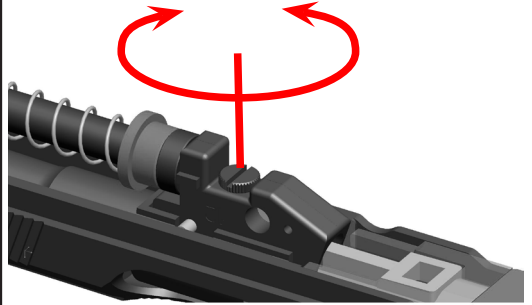

TURN ADJUST SCREW ACCORDING TO THE TREJECTORY

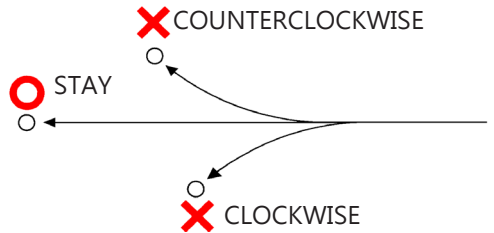

SP-01 Cal.6mm  
Exploded Drawing

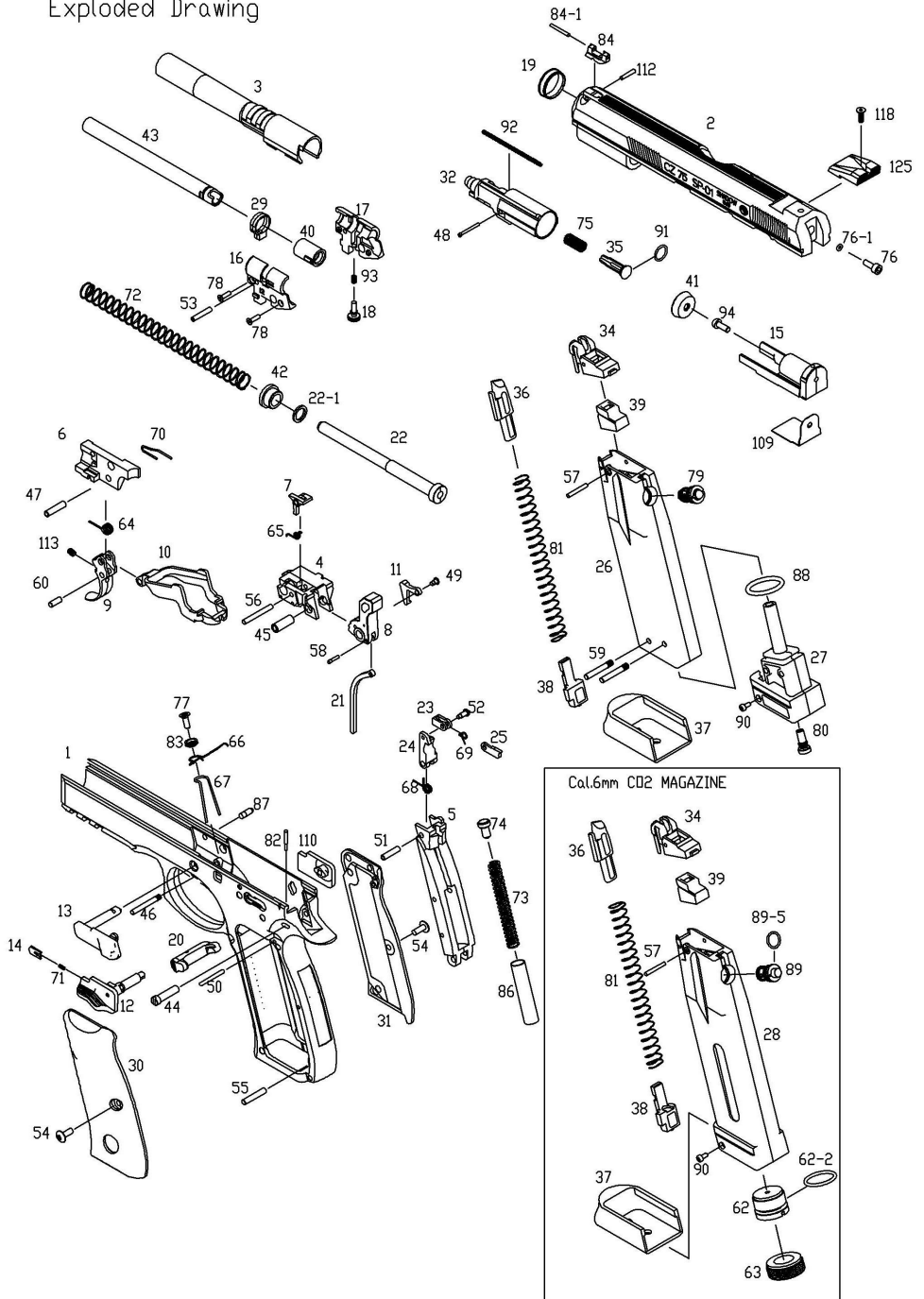

NO.	NAME	PRICE	NO.	NAME	PRICE
1	FRAME	2200	52	VALVE HAMMER PIN	40
2	SLIDE	1600	53	BARREL LOCKING PIN	80
3	OUT BARREL	600	54	GRIP SCREW	40
4	HAMMER HOUSING	300	55	MAIN SP HOUSING PIN	40
5	MAIN SP HOUSING	300	56	SEAR PIN	40
6	TRIGGER HOUSING	300	57	MAG LIP PIN	20
7	SEAR	80	58	HAMMER SP GUIDE PIN	20
8	HAMMER	300	59	MAG BOTTOM PIN	20
9	TRIGGER	300	60	TRIGGER BAR PIN	20
10	TRIGGER BAR	200	62	MAG STAB (CO2)	100
11	DISCONNECTOR	100	62-2	STAB O-RING	20
12	SAFETY	200	63	MAG BASE NUT (CO2)	100
13	SLIDE STOP	200	64	TRIGGER SP	30
14	SAFETY DETENT PLUNGER	60	65	SEAR SP	30
15	PISTON BLOCK	400	66	TRIGGER BAR SP	30
16	BARREL CHAMBER (L)	160	67	MAG CATCH SP	30
17	BARREL CHAMBER (R)	160	68	VALVE KNOCKER SP	30
18	TRAJECTORY ADJUST SCREW	120	69	VALVE LOCK SP	30
19	FRONT RING	120	70	SLIDE STOP SP	30
20	MAGAZINE CATCH	160	71	SAFETY SP	30
21	MAIN SP STRUT	60	72	RECOIL SP	60
22	RECOIL SP GUIDE	160	73	MAIN SP	60
22-1	RECOIL SP GUIDE PAD	40	74	MAIN SP CAP	40
23	VALVE HAMMER	120	75	FLOATING VALVE	20
24	VALVE KNOCKER	240	76	PISTON BLOCK SCREW	20
25	VALVE LOCK PLATE	120	76-1	PISTON BLOCK SCREW PAD	20
26	MAG BODY (GAS)	450	77	MAG CATCH SP SCREW	20
27	MAG BASE (GAS)	200	78	BARREL CHAMBER SCREW	20
28	MAG BODY (CO2)	450	79	EX VALVE	180
29	TRAJECTORY ADJUST RING	160	80	FILLING VALVE	80
30	GRIP (L)	240	81	FOLLOWER SP	60
31	GRIP (R)	240	82	HAMMER PIN DETENT	40
32	CYLINDER	180	83	MAG CATCH SP WASHER	30
34	MAG LIP	80	84	FRONT SIGHT	120
35	FLOATING VALVE	30	84-1	OPTICAL FIBER	30
36	MAG FOLLOWER	40	86	MAIN SP HOUSING SLEEVE	150
37	MAG BOTTOM	140	87	TRIGGER HOUSING PIN	20
38	MAG BOTTOM STOP	30	88	MAG BOTTOM O-RING	30
39	MAG GASKET	100	89	CO2 EX VALVE	240
40	RUBBER CHAMBER	100	89-5	CO2 EX VALVE O-RING(BIG)	20
41	PISTON RING	40	90	MAG BOTTOM STOP SCREW	20
42	RECOIL BUFFER	40	91	FLOATING VALVE O-RING	20
43	INNER BARREL	240	92	CYLINDER SP	30
44	HAMMER PIN	80	93	TRAJECTORY ADJUST SCREW	20
45	HAMMER SLEEVE	60	94	PISTON SCREW	10
46	TRIGGER PIN	60	109	PISTON BLOCK PLATE	200
47	TRIGGER SLEEVE	60	110	SAFETY RIGHT	200
48	FLOATING VALVE PIN	30	112	FRONT SIGHT PIN	20
49	DISCONNECTOR PIN	30	113	TRIGGER ADJUST SCREW	20
50	VALVE KNOCKER PIN	40	118	REAR SIGHT SCREW	20
51	VALVE KNOCKER SLEEVE	40	125	REAR SIGHT	150

# KJWORKS CZ-75 SP-01 MANUAL



Made in Taiwan under licence by ActionSportGames® A/S, Denmark and Česká Zbrojovka®  
, Czech Republic.

Česká Zbrojovka® Czech Republic and the logo are registered trademarks of Česká  
Zbrojovka® Czech Republic and are used



under worldwide exclusive license for Airsoft guns by ActionSportGames® A/S, Denmark.  
trademarks and designs are the property of proprietor and that the articles  
are produced under license from ActionSportGames® A/S.

# KJWORKS

Kjworks No.12 Lian-Ming 1st Street,Bade City,Taoyuan county,Taiwan  
Tel:03-3749793 Fax:03-3618130 e-mail:kjworks@ms47.hinet.net  
[www.kjworks.com.tw](http://www.kjworks.com.tw)